

# REVO VM II PRO

## OFF GRID Energy Storage Inverter

series **1.6/3.2/3.5/5.5kW**



### MPPT

Pure sine wave MPPT solar inverter  
Bulit-in 80/100A MPPT solar charger



### OFF-Grid

REVO VM II PRO series is suitable for  
off-grid applications.



### Battery

Battery equalization function extend life cycle  
Reserved communication port(RS485,CAN)for BMS



### Easy access

High PV input voltage range  
With touch buttons

### ● With battery connected

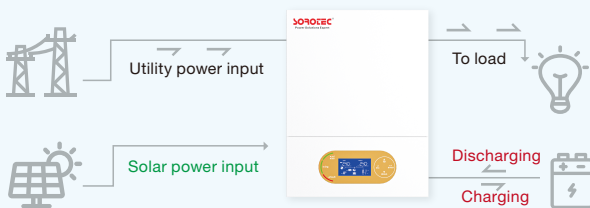

### ● Without battery connected

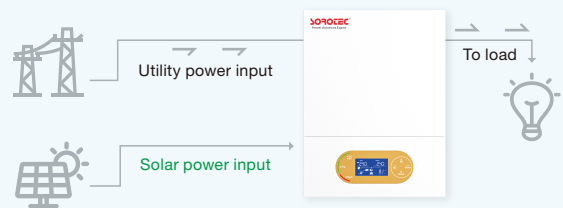

### ● Schematic diagram

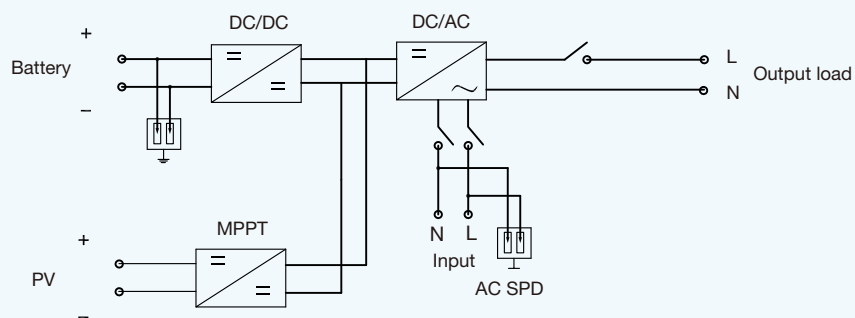

Technical Specification	REVO VM II PRO series			
Rated Power	1600VA/1600W	3200VA/3200W	3500VA/3500W	5500VA/5500W
<b>AC INPUT</b>				
Voltage	230VAC (220VAC/240VAC)			
Selectable Voltage Range	170-280VAC (For Personal Computers) ; 90-280 VAC (For Home Appliances)			
Frequency Range	50/60Hz (Auto sensing)			
<b>AC OUTPUT</b>				
AC Voltage Regulation (Battery Mode)	230VAC ± 5%			
Surge Power	3200VA	6400VA	7000VA	11000VA
Efficiency (Peak)	93%			
Transfer Time	10ms (For Personal Computers) ; 20ms (For Home Appliances)			
Wave Form	Pure sine wave			
<b>BATTERY</b>				
Battery Voltage	12VDC	24VDC	48VDC	
Floating Charge Voltage	13.5VDC	27VDC	54VDC	
Overcharge Protection	16VDC	33VDC	63VDC	
<b>SOLAR CHARGER AC CHARGER</b>				
Maximum PV Array Open Circuit Voltage	500VDC			
Maximum PV Array Power	2000W	3500W	4500W	5500W
MPPT Range Operating Voltage	60~450VDC		60~450VDC	
Maximum Solar Charge Current	80A		100A	
Maximum AC Charge Current	60A		80A	
Maximum Charge Current	80A		100A	
<b>GENERAL PARAMETERS</b>				
Operation Temperature	-10°C to 50°C			
Relative humidity	5% to 95% Relative Humidity (Non-condensing)			
Dimensions D x W x H(mm)	348*270*95		400*300*115	
Net Weight(KG)	5	5.5	8.5	9
<b>DISPLAY AND COMMUNICATION</b>				
Communication Interface	Standard:USB/RS232; Optional: CAN&RS485			
Safety standard	EN/IEC62109-1,EN/IEC62109-2			